

## Elevation

### CENTRA SQUARE 13'-4" - CS40

Designed to 90mph, Exp. B  
 Rated when umbrella is fully erected.  
 Umbrella weight: 194 lb

Overall dimensions represent clearance dimensions for the complete umbrella. Membrane dimensions differ, depending on variations in tensioning and fabrication. All dimensions are nominal and have a tolerance of +/- .2".

Note : The umbrellas must be closed and tied before wind speeds reach gusts of 60mph (100km/h) Refer note on Specification - Umbrella Design.

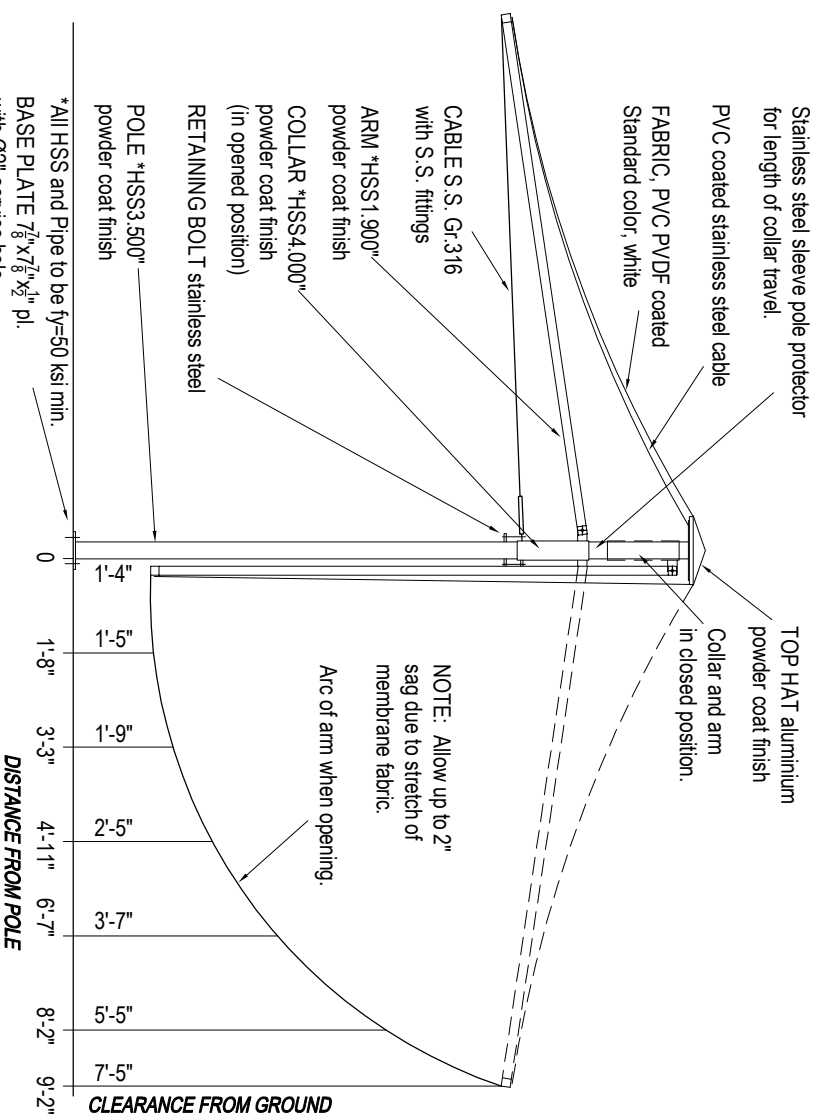

## 13'-4" Center Support Square Umbrella Centra - Model CS40

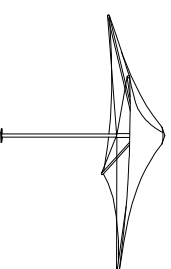

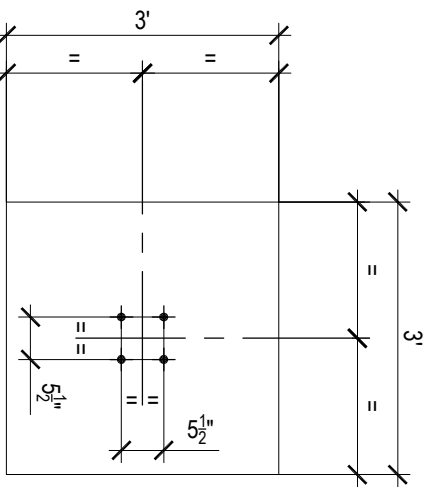

Plan

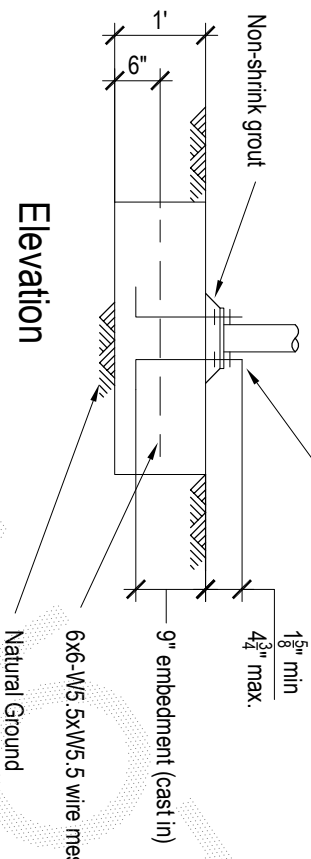

Elevation

## CS40 - Pad Footing

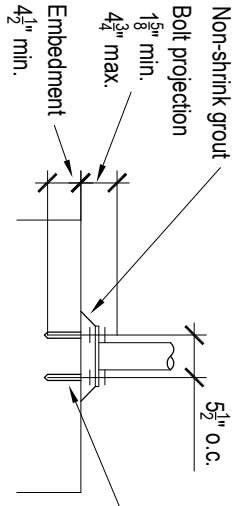

## Chemical Anchor Detail

4- $\frac{1}{2}$ " H.D. bolts to be threaded rod grade F1554 Gr. 36 hot dipped galvanized, or stainless steel Gr.316. Supplied with nuts, washers and leveling nuts. Chemical anchors, at  $\frac{5}{2}$ " x  $\frac{5}{2}$ " centers to be "Hilti HVU", or engineer approved equivalent, and to be installed in accordance with the manufacturer's instructions. Hole to be clean and dry at time of installation.

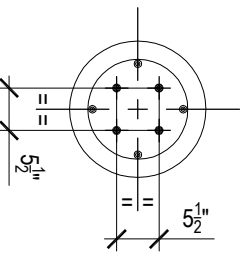

Plan

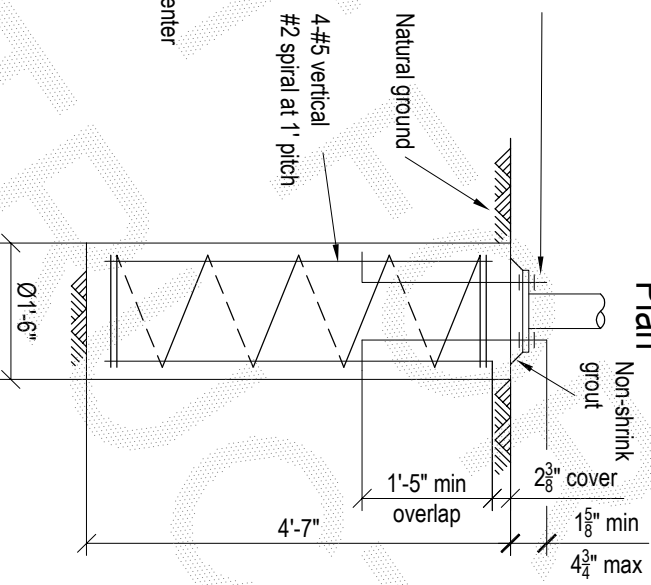

Elevation

## CS40 - Pier Footing

- Notes:**
- Designed to 90mph, Exp B
  - Assumed soil conditions:
  - Pad - bearing capacity 14.5 psf
  - Pier - cu=7.25 psf (stiff clay)
  - Minimum  $2\frac{3}{8}$ " cover to all reinforcement
  - Concrete strength -  $f_c$  3600 psi.
  - $\frac{3}{4}$ " aggregate size
  - Slump  $2\frac{1}{2}$ "
  - Anchor bolt location tolerances per Australian Standard AS 4800-1998**
  - 3mm for anchor bolt centers within an anchor bolt group.
  - 6mm for adjacent anchor bolt group centers.
  - Maximum accumulation of 6mm per 30m not to exceed a total of 25mm.
  - 6mm from anchor bolt group center to column line center.

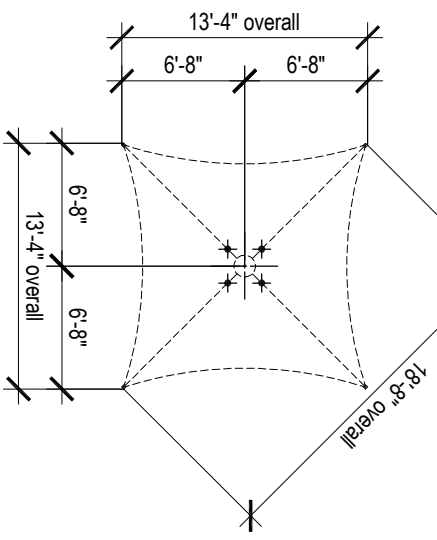

H.D. Bolt Layout Plan  
Not to scale